

NARA GUARD

# USER MANUAL

High Flow Pipeline Filtration System





## CONTENTS

<b>1. Product &amp; Accessories .....</b>	<b>01</b>
<b>2. Functional Schematic Diagram .....</b>	<b>01</b>
<b>3. Cartridge Usage &amp; Maintenance .....</b>	<b>02</b>
<b>4. Troubleshooting .....</b>	<b>05</b>
<b>5. Caution .....</b>	<b>05</b>



## PRODUCT & ACCESSORIES

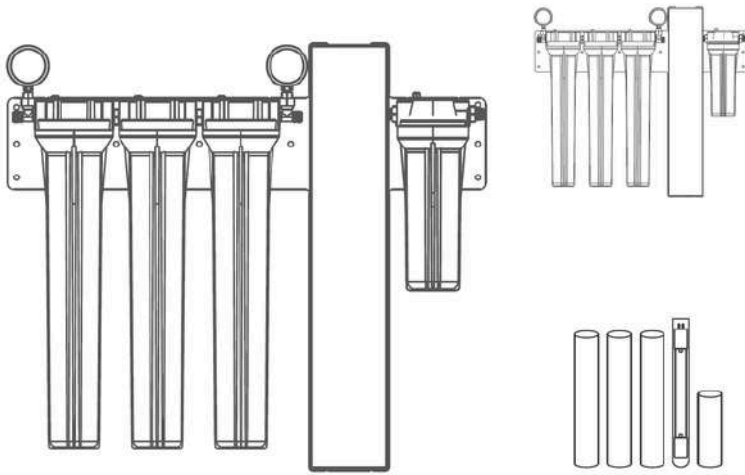

Main body x 1pc

Filter cartridge x 4pcs + UV sterilizer x 1pc

PP Spun Cartridge, Block Coconut Carbon Cartridge, PL Pleated Cartridge, UV Sterilizer, Compound Filter (PP+Siliphos Cartridge)



Wrench

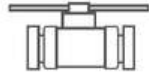

Inlet Water Valve



Manual



Ballast



Pressure Gauge x 2pcs

## FUNCTIONAL SCHEMATIC DIAGRAM

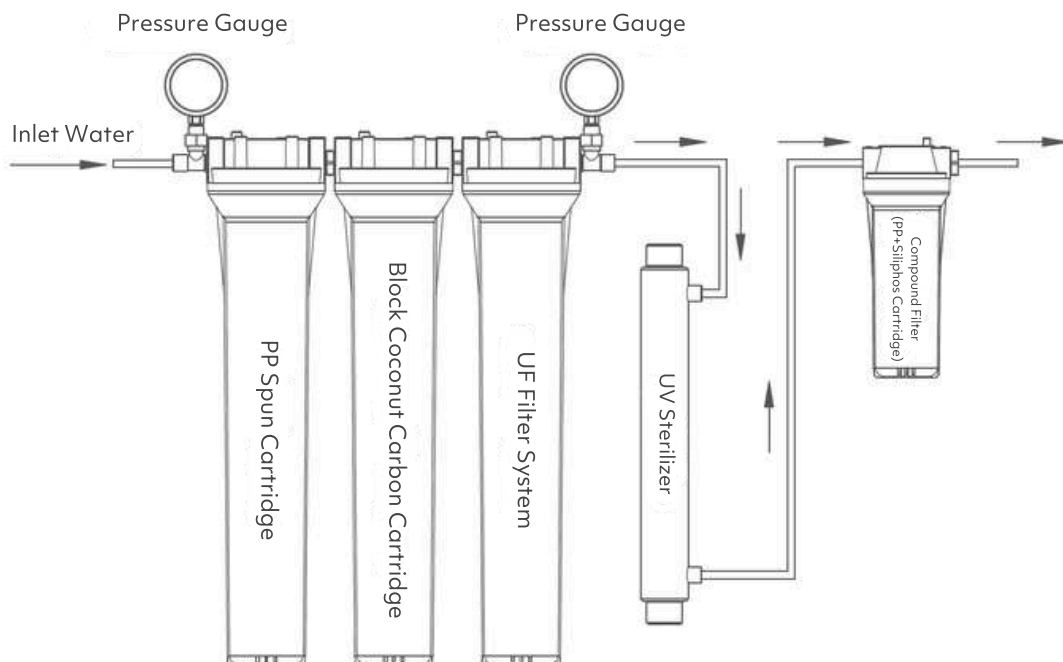



## CARTRIDGE USAGE & MAINTENANCE

### ✓ Cartridge Function

#### 1. PP Spun Cartridge

It can effectively remove impurities in water such as suspended matter, small particle, rust, etc.

#### 2. Block Coconut Carbone Cartridge

It can absorb chlorine, organic matter, heavy metal and other harmful matters.

#### 3. Ultra Filtration

A UF (Ultrafiltration) filter uses a very fine membrane to remove bacteria, viruses, and suspended impurities from water while retaining essential minerals, providing safe and clear drinking water without water wastage

#### 4. UV Sterilizer

It can kill bacteria in water.

#### 5. Compound Filter (PP+Siliphos Cartridge)

PP (Polypropylene) sediment filter with Siliphos crystals to remove dirt, sand, and rust while preventing limescale buildup in pipes and appliances.

### ✓ Cartridge Maintenance

To ensure the unit operates at its optimum level, routine maintenance is required. The frequency of maintenance depends on the inlet water quality and amount of system usage. Below are some guidelines for scheduled cartridge changes, keep in mind the frequency of filter changes may vary. If in doubt, contact your local dealer or service technician.

1. Change PP Spun Cartridge every 3 months.
2. Change Block Coconut Carbone Cartridge every 6 months.
3. Change Ultra Filtration cartridge every 6 months.
4. Change UV Sterilizer every 24 months.
5. Change Compound Filter (PP+Siliphos Cartridge) every 6 months.



## ✓ Install Cartridge

Turn off the water and cut the power supply before installation.

1. Use wrench to remove filter housing.
2. Remove filter cartridge from packaging.
3. Insert cartridge into filter housing.
4. Install filter housing and tighten with wrench provided. Please check O ring before tightening otherwise there will be a risk of water leakage.

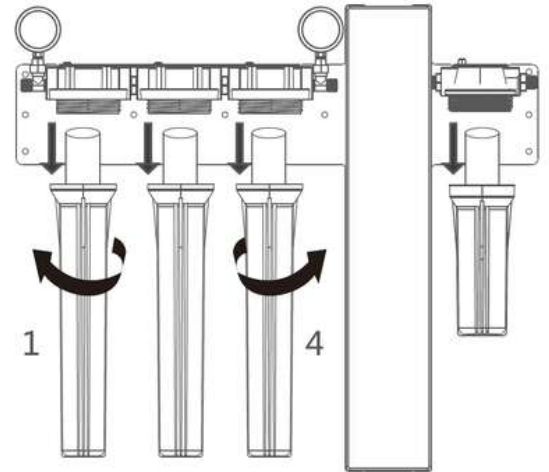

## ✓ Install UV

1. Place silicone Stopper (D) at the tip of quartz tube (Item B). See Figure 1.
2. Slid-in the quartz tube (Item B) into the UV chamber (Item A). See Figure 2.
3. Fasten the metal nut (Item C) to seal UV chamber (Item A). See Figure 3.
4. Plug the Adaptor (Item F) to the UV lamp (Item E). Does not touch the glass part. See Figure 4.
5. Insert UV lamp (Item E) in to UV Chamber (Item A). See Figure 5.
6. Seal it up with the rubber stopper that is already attached to the Adaptor (Item F).
7. Install the flexible tube and correctly specify it on the bracket according to the sequence shown in Figure 7.
8. Install the Protective cover, fasten screws, See Figure 8.

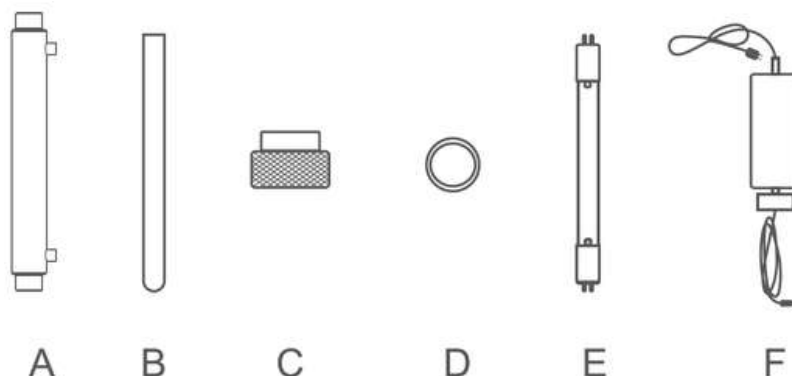

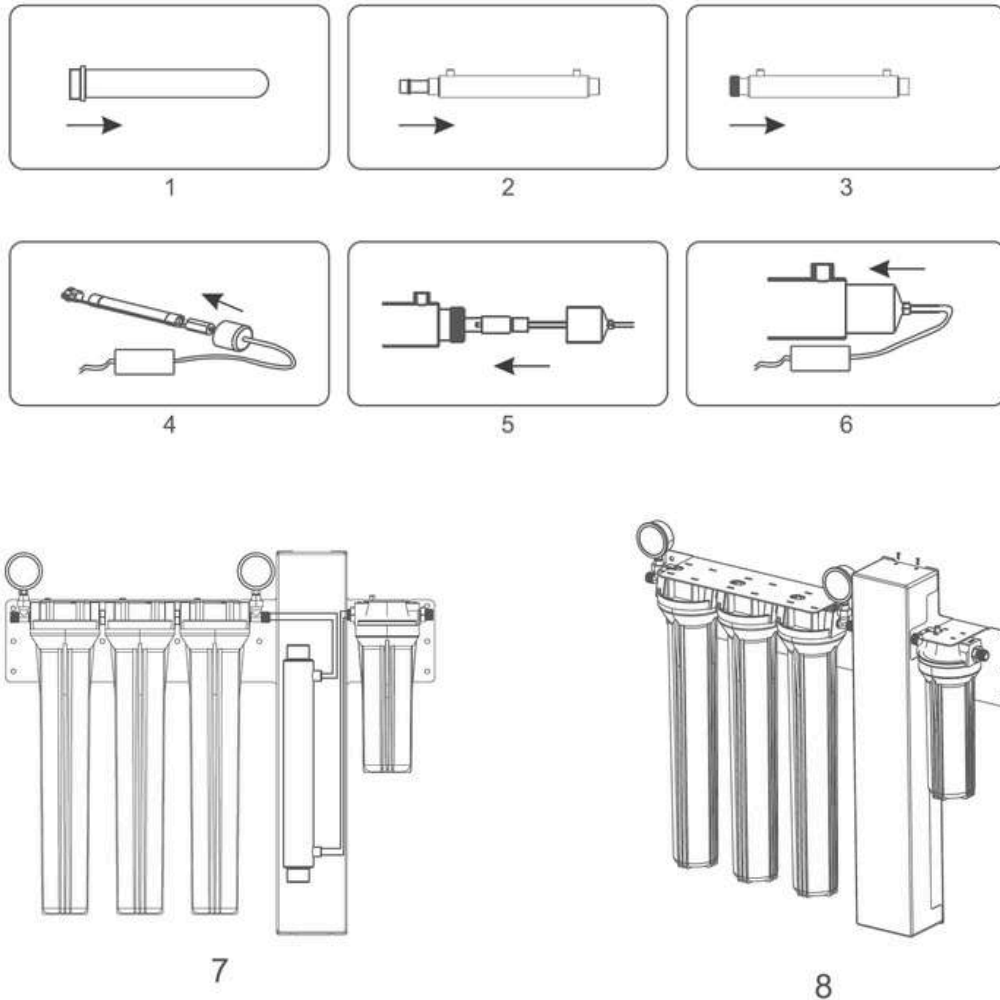

## ✓ Sign To Replace Cartridge

1. Output water flow decreases obviously, it's caused by blocked cartridge.
2. Output water flow increases obviously, it's caused by broken cartridge.

## ✓ Replace Cartridge

Turn off the water and cut the power supply before installation.

1. Use wrench to remove filter housing.
2. Take out filter cartridge from filter housing and discard it.
3. Insert new cartridge into filter housing.
4. Install filter housing and tighten with wrench provided.

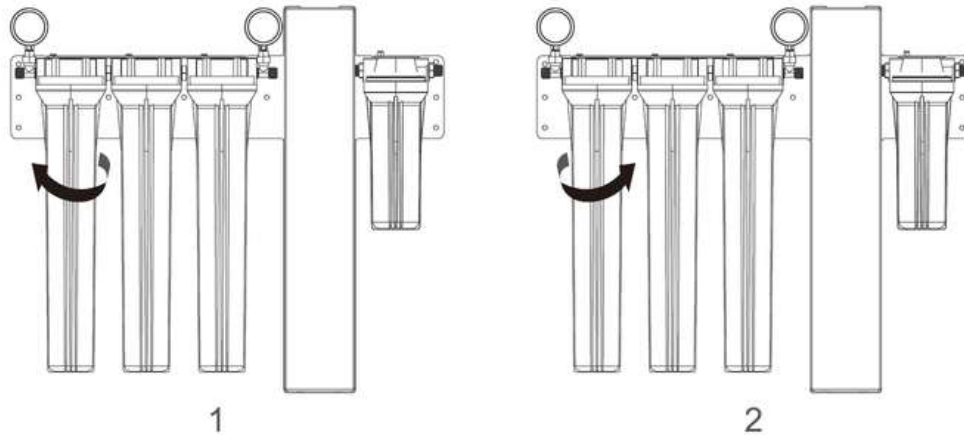

## TROUBLESHOOTING

Trouble	Cause	Solution
No purified water/ Purified water flow is small.	1. Filter cartridge is blocked	1. Replace cartridge
	2. Inlet water valve is closed	2. Open the inlet water valve

## CAUTION

### **Caution**

1. Clean purifier and replace filter cartridges regularly.
2. Do not disassemble, open, or modify this unit. Tampering with the unit may cause failure or damage and will void warranty.
3. Please ensure you are using the correct power source.
4. Unplug the power plug and turn off the ball valve if you are not going to use it for a long time to come.
5. Do not install the unit in an environment where the temperature is below 4 °C.
6. Handle with care during loading& unloading, transportation and installation.



## **Reminder**

1. Please turn off the feed water ball valve and cut off the source water to avoid the "water hammer phenomenon" which may lead to leakage or damage to housings and filters if you go out in daytime or after the last use at night. Our company would not take the responsibility of the consequences caused by this situation.
2. Please cut off power and source water at once in case troubles occur and ask professional staff to repair.
3. Professional staff are advised to replace cartridges.



NOTE: Water hammer is a pressure surge or wave caused when water in motion is forced to stop or change direction suddenly. When resident in building closes his valve suddenly, a pressure wave propagates in the pipeline of building.

K L O U D

Nara Guard



KLOUD™ | DESIGNED IN UAE

[www.kloudfilter.com](http://www.kloudfilter.com)

Water, The Way It *Should* Be \_\_\_\_\_ 